

# VOLTAGE REGULATION OF THE DISTRIBUTION GRID

Bob McFetridge

Voltage Regulation and Power Quality Track  
Monday and Tuesday Sessions



## **SESSION 2 – General theory of coordination of voltage regulation.**

## Differences Between Regs and Caps

1. Regulators and LTCs are uni-directional devices. They impact the voltage on the load side of the device but have little impact on the source side of the device.
2. Capacitors are bi-direction in that they will impact both the upstream and downstream voltage.
3. Regulators are a series device and a voltage source.
4. Capacitors are a shunt device and a impedance-based current source.
5. Regulators impact the voltage the same amount no matter the location.
6. Capacitors impact on the voltage is made up of two components, the size of the bank and the amount of reactive impedance between the capacitor bank and the source. The more impedance, the greater the voltage change. Another way of stating this is the weaker the system the more voltage rise.

## Voltage or Power Factor

1. LTC and Regulator controls typically use the voltage to decide when to operate
2. Capacitor Banks typically use either voltage or Vars to decide when to operate
3. When a regulator taps (up or down) it impacts the voltage only and only on the load side of the device.
4. When a capacitor operates (open or close) it impacts the voltage and the power factor and the voltage change is seen on both sides of the capacitor bank

## Why Power Factor is Important

1. Reactive Current (typically inductive) causes 2-6 times more voltage drop than real current.
2. Reactive current reduces the grid capacity (transformers and cable are rated off of MVA) so the more reactive current following reduces the amount of real current that can flow.
3. Capacitive current can be generated from the generators which have to flow through the transmission Grid to get to the distribution Grid or from cap banks.
4. Distribution Vars are cheaper to install then getting the Vars from the transmission system.

## What is the Desired Power Factor

1. With the retirement of inertia-based rotating generators to the inverter-based renewables the transmission grid is becoming weaker and requiring more reactive voltage support.
2. The transmission to distribution substation power transformer consumes inductive VARs due to its impedance.
3. Typically, the distribution low-side bus needs to be 0.98 leading in order to provide the VARs for the transformer and have the distribution system be Var Neutral to the transmission system.
4. Under emergency conditions it may be advantageous to be even more leading to provide VARs into the transmission system.

## What Comes First Voltage or pF?

1. Since the cap banks are the main source to control the pF and it also impacts the voltage the pF should be controlled first.
2. Once the pF on each feeder is slightly leading then the voltage should be addressed via regulators or LTCs.
3. Therefore, coordination has to be done between the capacitor banks and the LTC/regulators.

## Traditional Circuit Design

- Without and Voltage Regulation this is how the typical feeder circuit operates.
- The Voltage is highest at the source.
- The load is greatest near the source causing the most voltage drop.
- As the load decreases near the end of the circuit so does the percentage of voltage drop.

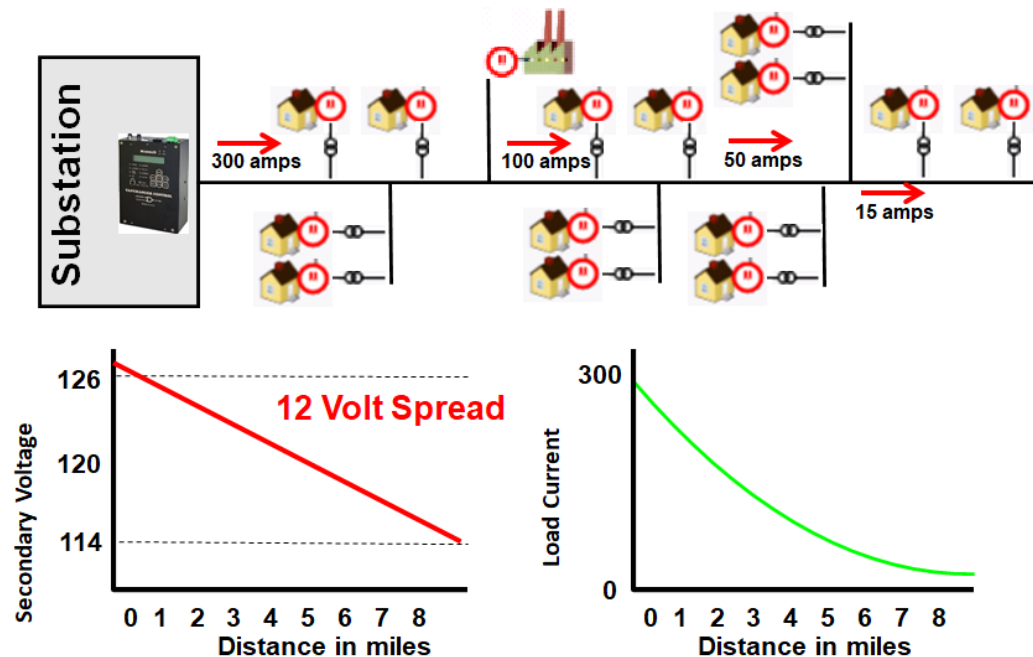

**Voltage Profile – Loads Only Feeder Regulated**

## Traditional Circuit Design - Regs

- On the previous slide with no regulation there was a 12 V drop so the source was at 126 V and the end-of-the-line was at 114.
- By adding a line regulator at the mid-point of the feeder the voltage drop is now 6 volts between the source and the regulator and again 6 volts between the regulator and the end-of-the-line .In this example the voltage at the source is 123 and drops to 117 before the regulator. The regulator steps it back up to 123 and it falls to 117 at the EOL.
- The feeder has a 6 volt variation across it now as opposed to a 12 volt with no regulation but the slope is the same.
- The slope is mainly caused by reactive current

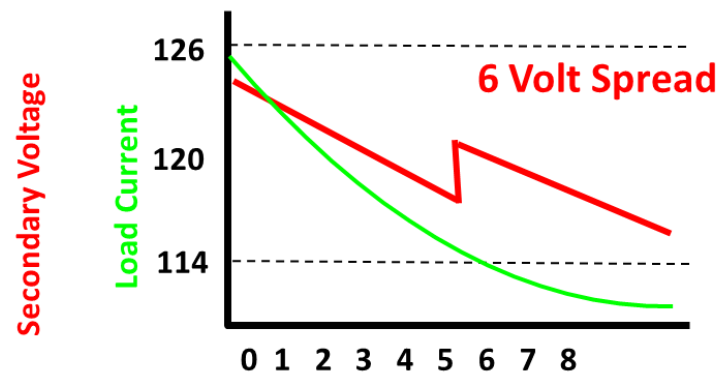

## Traditional Circuit Design- Regs

- One can see both the advantage and dis-advantage of using the line regulator.
- The advantage is that the regulator can provide 10% boost or buck in 33 increments.
- The disadvantage is that it is uni-directional.

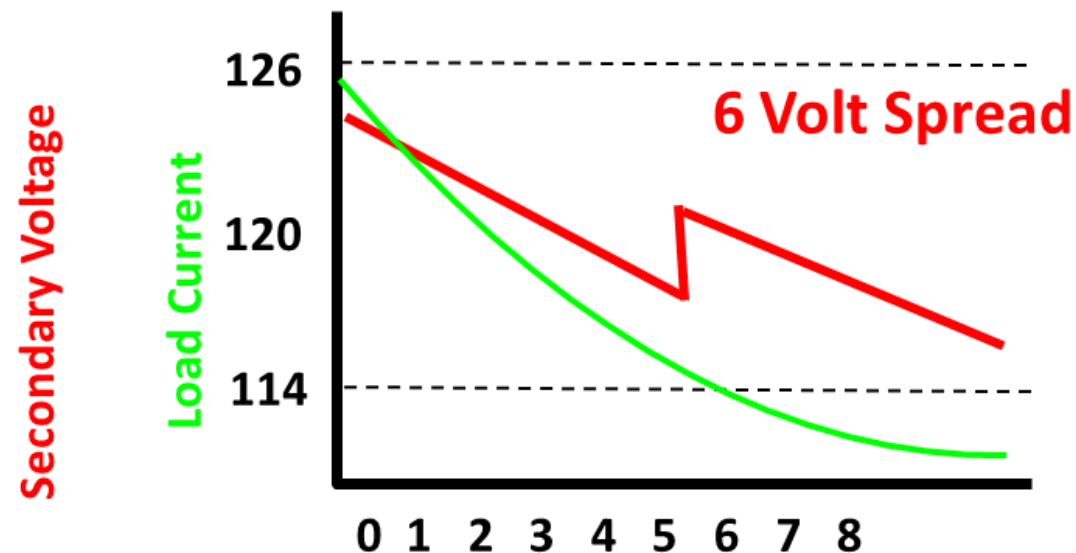

## Traditional Circuit Design - Regs

- One can see both the advantage and dis-advantage of using the line regulator.
- The advantage is that the regulator can provide 10% boost or buck in 33 increments.
- The disadvantage is that it is uni-directional.
- This means there are large step changes from the end of one regulating zone to the beginning of the next. The regulators are shifting the voltages up and down and chopping of the slope, but they are not flattening the slope of the voltage drop.

# Traditional Circuit Design - Regs

- As the circuit gets longer and more heavily loaded additional regulators are required.
- Regulators are a series device and adds impedance to the feeder making it weaker. After 2 sets of line regulators the next set of line regulators can make the end of the circuit too weak. Now when a customer's air conditioner kicks in their lights dim. It also reduces the fault current at the EOL making it more difficult to detect faults versus load current.

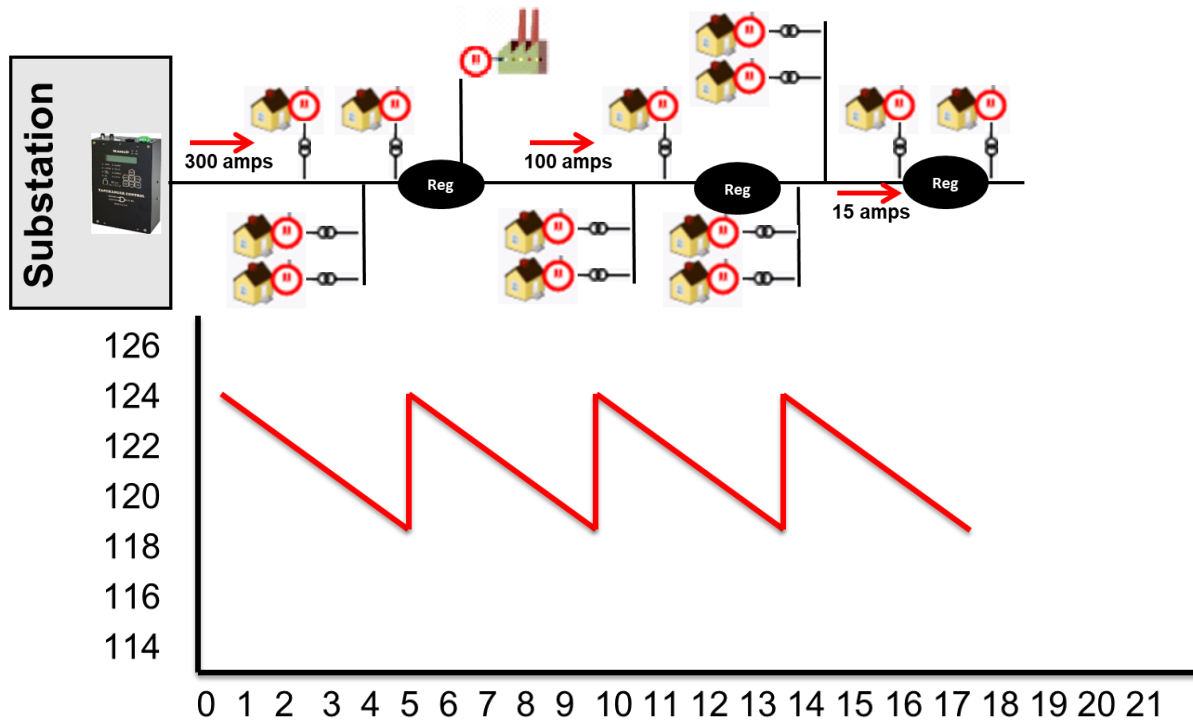

# Traditional Circuit Design - Caps

- What if we replace the regulators with voltage controlled switched capacitor banks.

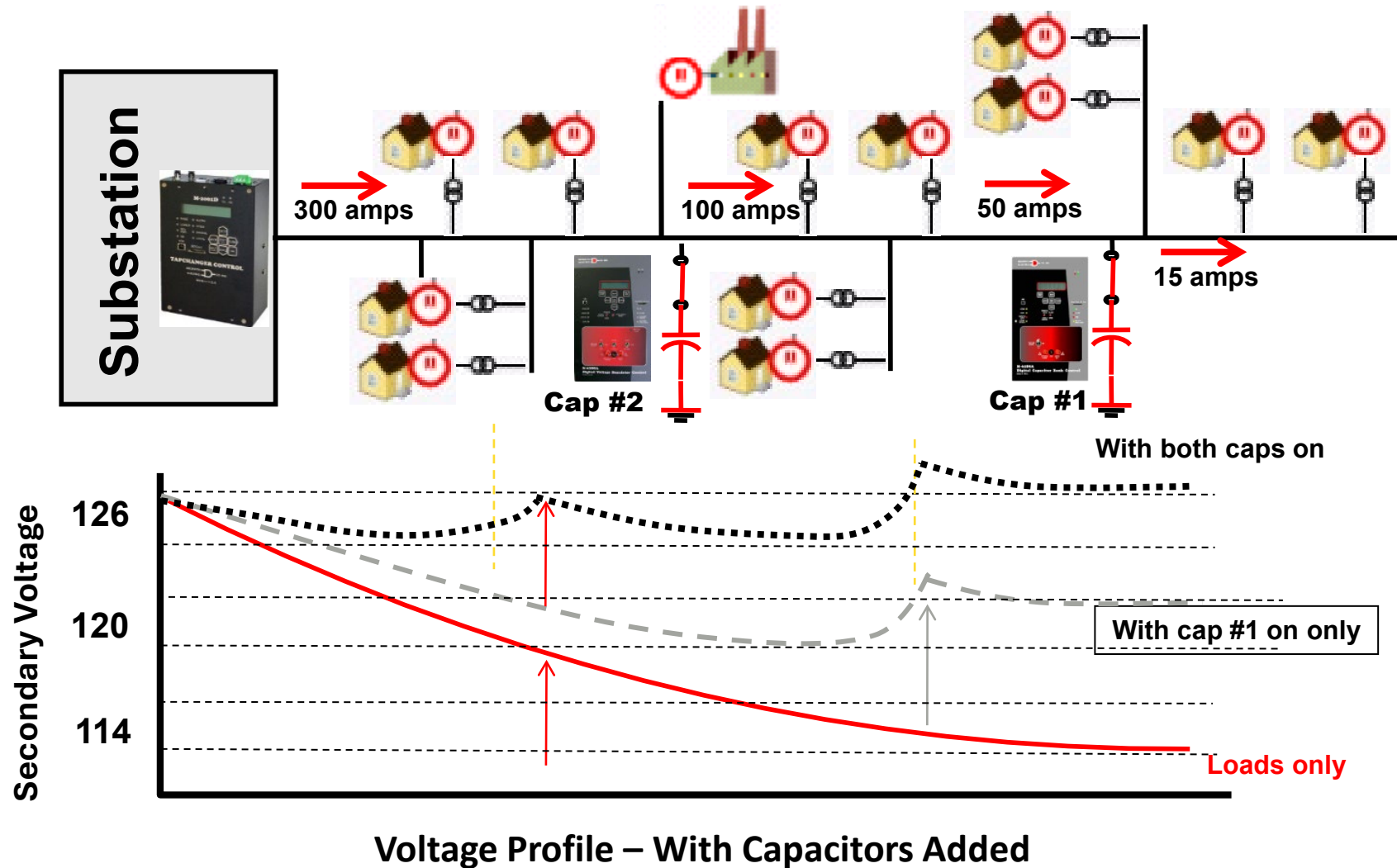

## Traditional Circuit Design - Caps

- One can see the voltage rise on both sides of the capacitor bank as opposed to only the load-side of the regulators
- The Capacitor near the end of the circuit will create a larger voltage rise due to the weaker source. It is kicking up the EOL voltage to flatten the voltage

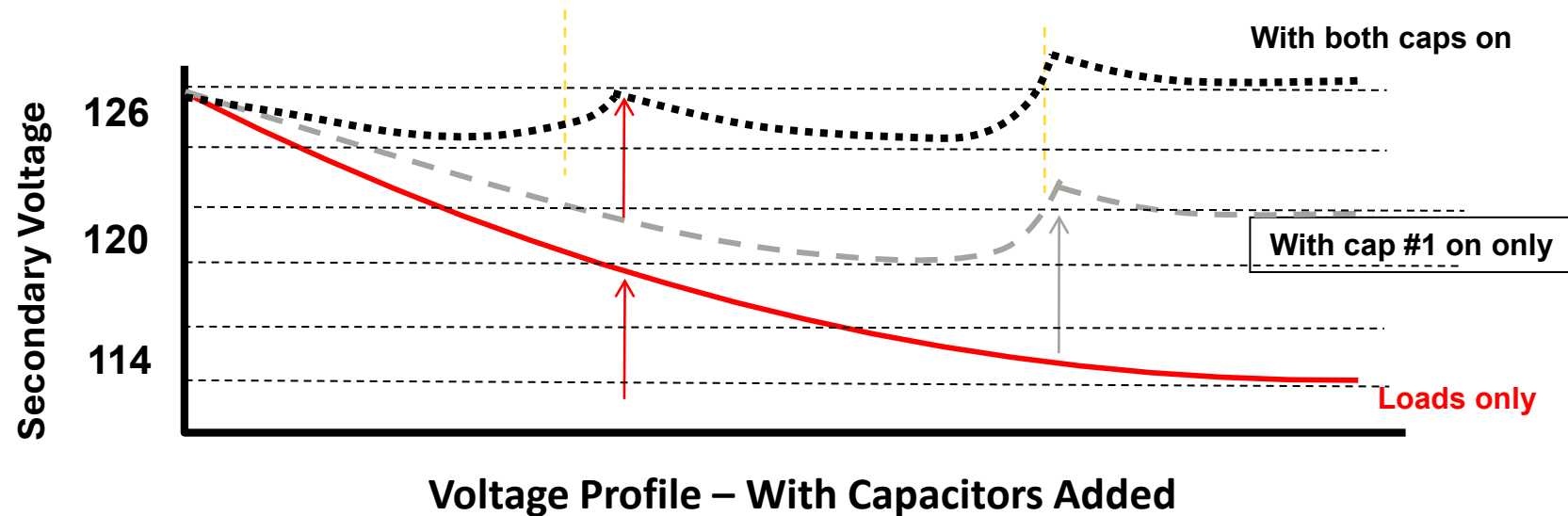

## Flip the Feeder

- With the Voltage unregulated or with regulators the lowest voltage on the circuit is at the end of the regulating zone.
- With the capacitor solution the voltage has a flatter profile, and the lowest voltage is not at the end of each zone but closer to the source.
- With the higher voltages at the end of the feeder and the lower voltages at the beginning we have flipped the voltage profile.
- The capacitors are also pushing Vars back towards the substation and getting the pF to unity or slightly leading.

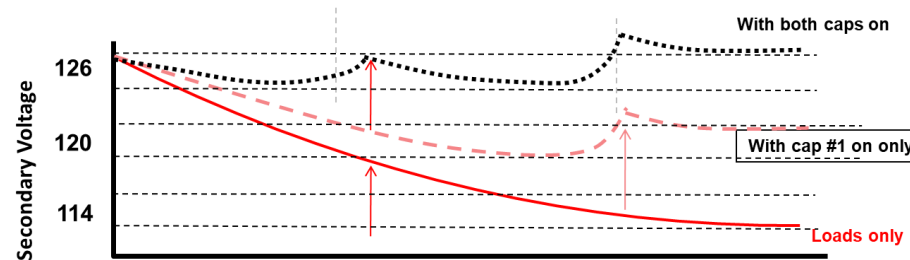
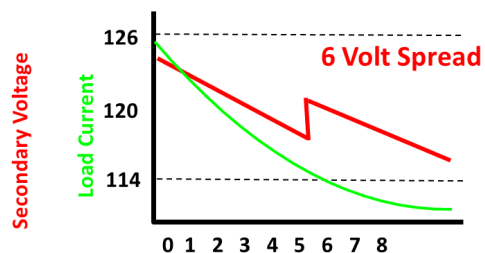

Voltage Profile – With Capacitors Added

## Grid Coordination

- If the pF is lagging and voltage is low it is desirable to allow a capacitor bank to close, taking operations off the LTC and improving power factor and increasing system capacity while reducing line losses and raising the voltage.
- If the pF is leading and the voltage needs to be lower, allow a capacitor bank to open, taking operations off the LTC and improving power factor and increasing system capacity while reducing line losses and decreasing the voltage.
- If pF is lagging and voltage needs to be lower, LTC or regulator should tap.
- If pF is leading and the voltage needs to be raised, allow the LTC or regulator to tap.
- If the pF is in the desired band (0.98 lag to 0.98 lead) and the voltage is out of band the LTC or regulator should tap.

## Grid Coordination

- In order to flatten the slope, the voltage at the EOL needs to come up and the front end voltage needs to go down.
- To raise the EOL voltage the capacitor banks furthest from the source need to be the first to close and last to open.
- The cap banks closest to the source need to be the first to open (to lower the front end voltage) and last to close.
- Use of gang operated voltage controlled cap banks is best suited
  - Voltage controlled don't require extra equipment line post sensors and therefore the less expensive option.
  - Using voltage control makes it easier to coordinate with the LTC and regulators.
  - Voltage control cap banks are easier to locate (don't have to be on the main trunk of the circuit but can be installed on taps and laterals).

# Grid Coordination

- Cap Banks with Coordinated time delays.
- If regulator or LTCs are upstream of the cap banks their time delays should be longer than the cap bank time delays.
- The Cap Bank Close Voltage should be set higher than regulator low bank to allow it to close before the regulator taps. Likewise, the Open should be lower than the regulator upper band to allow a cap bank to open before the regulator taps.

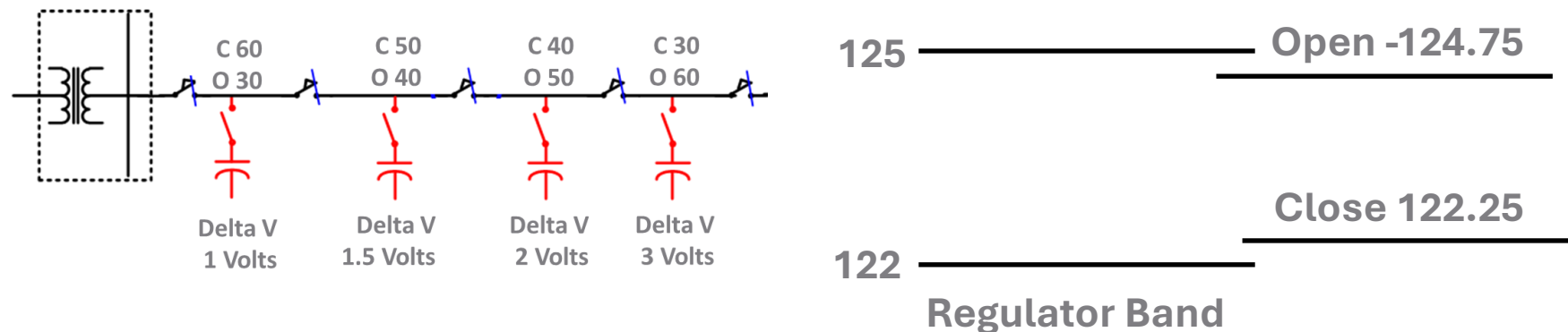

## Grid Coordination – Delta V

- The Delta V is the voltage changed caused at the cap bank when it operates.
- Need to keep the Delta V smaller than the bandwidth of the LTC and regulators (in this case the Delta V needs to be less than 2.5).
- Time Delays of cap banks should be smaller than the upstream LTC or regulators.

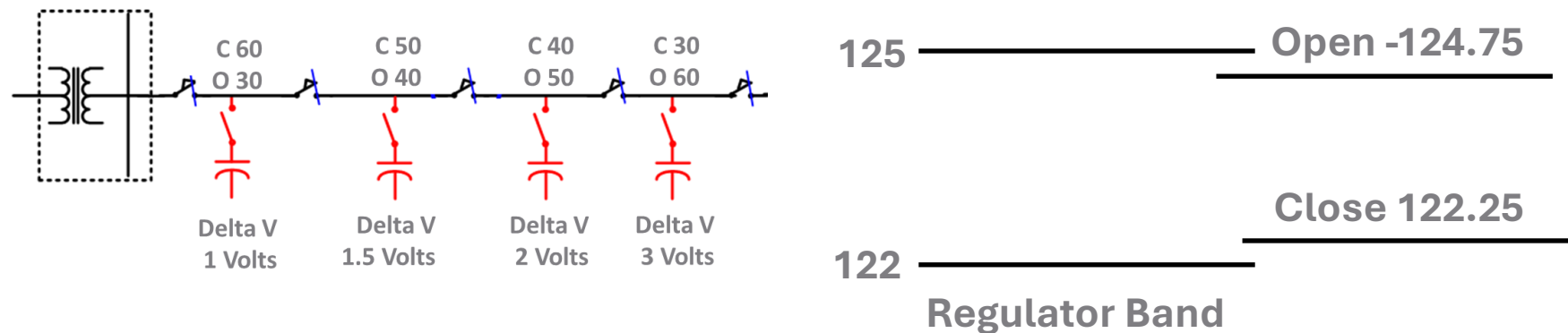

## Summary

- Left unregulated there will be a voltage drop from the source to the EOL.
- Every Revenue meter needs to be between 114 and 126 VAC. This measurement is on the 120/240 secondary and the regulation is done on the primary.
- Most utilities allow for a 3-4 volt drop on the secondary therefore the primary voltage should be regulated between 117 and 126.
- In order to be able to have the regulators/LTC move the voltage up and down the slope of the voltage drop must be flattened.
- Due to high X/R ratios it is typically advantageous to have capacitor banks on the back end of the circuit close to bring the EOL voltage up.

## Summary

- By having each feeder circuit run slightly leading three benefits are met:
  - The distribution Grid is providing all the Vars required and is Var neutral to the transmission grid. This frees up capacity on transformers and transmission lines.
  - When there are leading Vars at the source this is an indication that the source is at a lower voltage than other parts of the circuit.
  - By having the cap banks regulate the voltage under normal conditions we have reduced operations on more expensive apparatus (LTC and regulators) that have moving parts and require maintenance.

## Summary

By flattening the Voltage profile across the feeder, the following can be accomplished:

- The feeder can be operated at lower voltages.
  - Peak Shaving benefits.
  - Increased solar hosting capacity.
  - Long term Conversation Voltage Reduction (CVR) to reduce green-house gas emissions.
  - Deeper load reduction for emergency situations (traditional voltage reduction).
  - Increase the available capacity on existing assets.

**Bob McFetridge –Hubbell  
Utility Solutions – Beckwith  
Electric**

**919-675-3372**

**910-777-4910**

**[bmcfetridge@hubbell.com](mailto:bmcfetridge@hubbell.com)**

**[www.BeckwithElectric.com](http://www.BeckwithElectric.com)**

**(727) 544-2326**