

# VOLTAGE REGULATION OF THE DISTRIBUTION GRID

Bob McFetridge

Voltage Regulation and Power Quality Track  
Monday and Tuesday Sessions



## **SESSION 4 – Capacitor banks and controls.**

## Substation Switched Capacitor Banks

1. Used to provide the Vars to cancel out the impedance of the Substation Power Transformers.
  - a. For this use case the cap banks should be in when the transformer is in-service and switched out when the transformer is out of service. The size of the bank should be calculated by determining the Vars required by the transformer and this should be a single stage cap bank.
2. Used for power factor correction so as not to pay power factor penalties to the Power Provider.
  - a. Typically, a 2-staged switched bank with each stage being a different KVAR As an example stage 1 could be 600 KVAR and stage 2 1200 KVAR. This would provide 3 steps, 600, 1200 and 1800.

## Substation Switched Capacitor Banks

3. Used to provide Vars to downline inverters operating in either fixed PF or volt/Var modes.
  - a. Typically, a multi-staged switched bank with each stage being a different KVAR sized to match the Var requirements for each inverter-based DER on the bus. If there are multiple DERs then there should be multiple steps.

## **Substation Switched Capacitor Banks**

Substation Cap Banks are always gang-operated (all three phases or either open or closed).

Substation Cap Banks may require a zero-crossing close switch to minimize voltage spikes that can occur when switching in larger banks.

Substation Cap Banks can be switched automatically either with voltage or Var control and can also be controlled remotely via SCADA.

## Fixed Capacitor Banks

1. Used to provide VARs requirements during the lightly loaded times of the day and would normally always be on.
2. Can also be used for seasonal load requirements (on in the summer of A/C, off in the winter, or on during irrigation season and off during the rest of the year).

# Switched Capacitor Banks

1. Used to provide voltage support and Vars for the feeder circuit
2. Requires capacitors, switches, distribution voltage transformer, fuses and cutouts as well as a controller

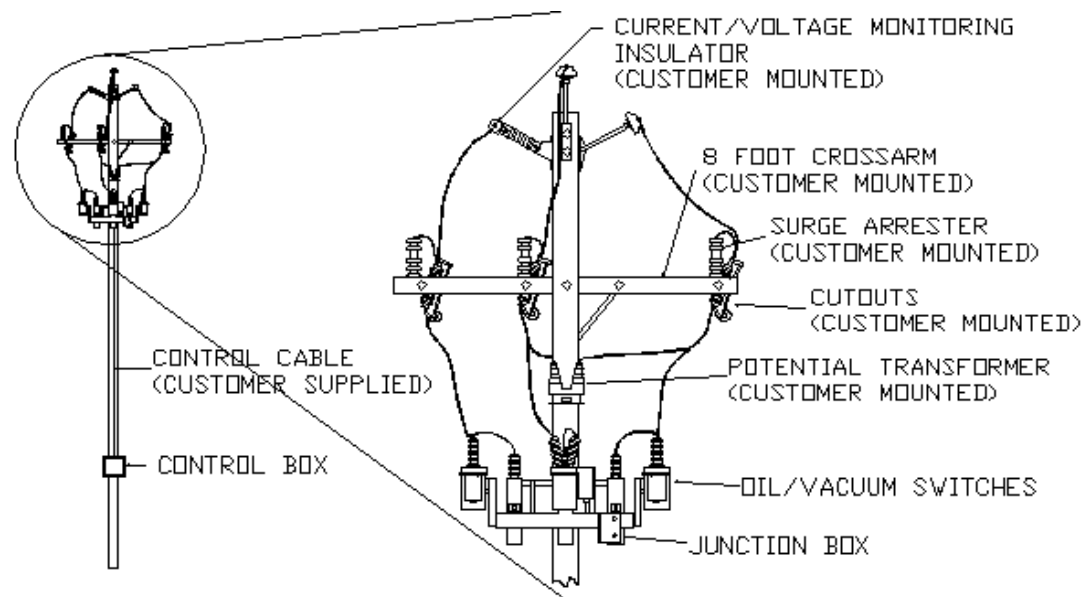

## Gang Operated or Independent

1. Most switched cap banks act like LTC or Substation Cap banks in that they sense one phase and operate all three phases together, known as gang-operated.
2. Newer installations permit individual phase operation but requires a smarter control and additional sensors to make measurements on all three phases.
3. Individual Phase Operation is good for balancing the voltage or Vars on feeders that don't have single-phase voltage regulation (an LTC at the source and no line regulators).

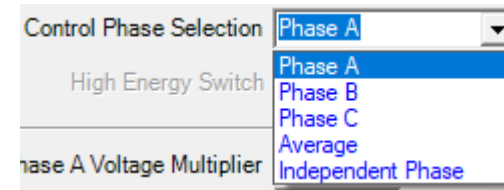

On the M-6283A three phase control the control phase can be selected from CapTalk to operate the bank:

1. As a single-phase control selecting the operating phase (A, B or C)
2. As a three-phase control using the average for the three phases
3. As an Independent Phase (triple-single) control operating each phase independently.

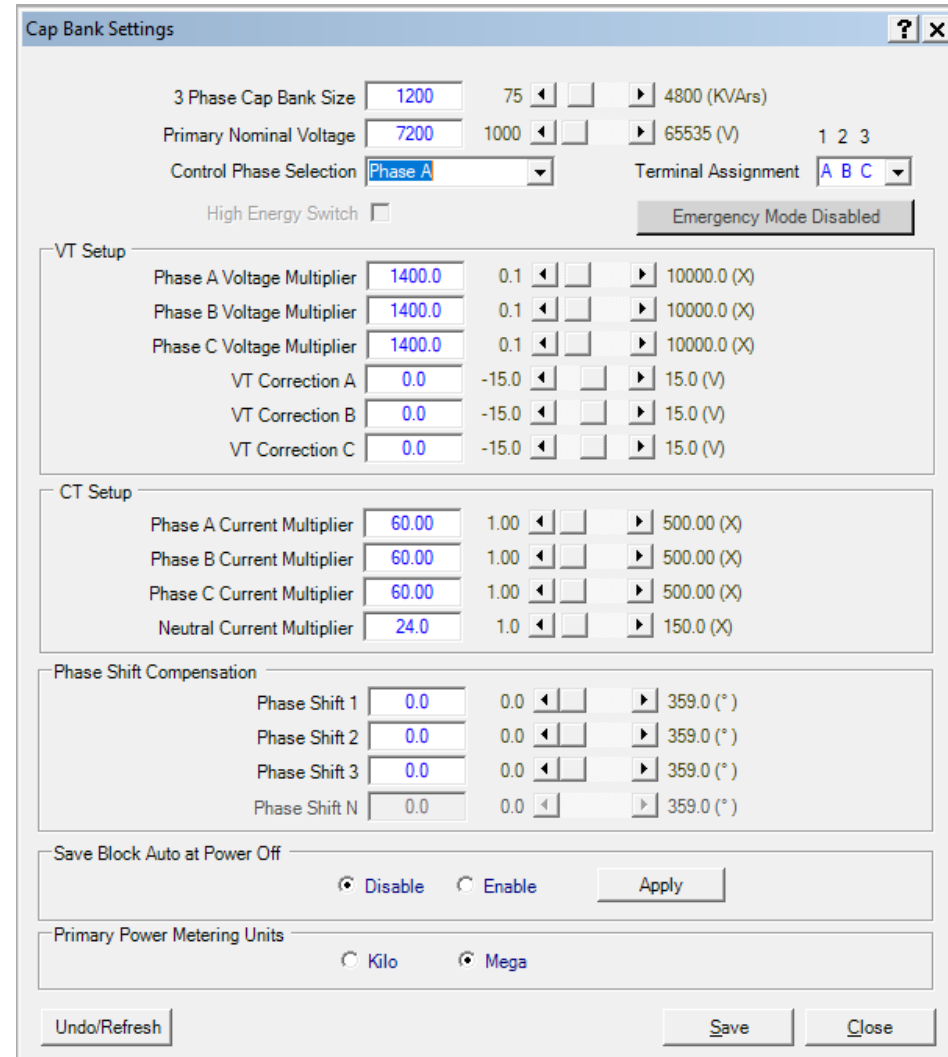

## Cap Bank Assemblies

1. Capacitor banks are normally ordered with a certain primary voltage and KVAR rating.
2. They normally come mounted in a rack with the motor or vacuum operated switches, fuses and cutouts, transformer and control, and possibly line post sensors and a complete package.

# Switched Capacitor Banks

1. Used to provide voltage support and Vars for the feeder circuit.
2. Requires capacitors, switches, distribution voltage transformer, fuses and cutouts as well as a controller.

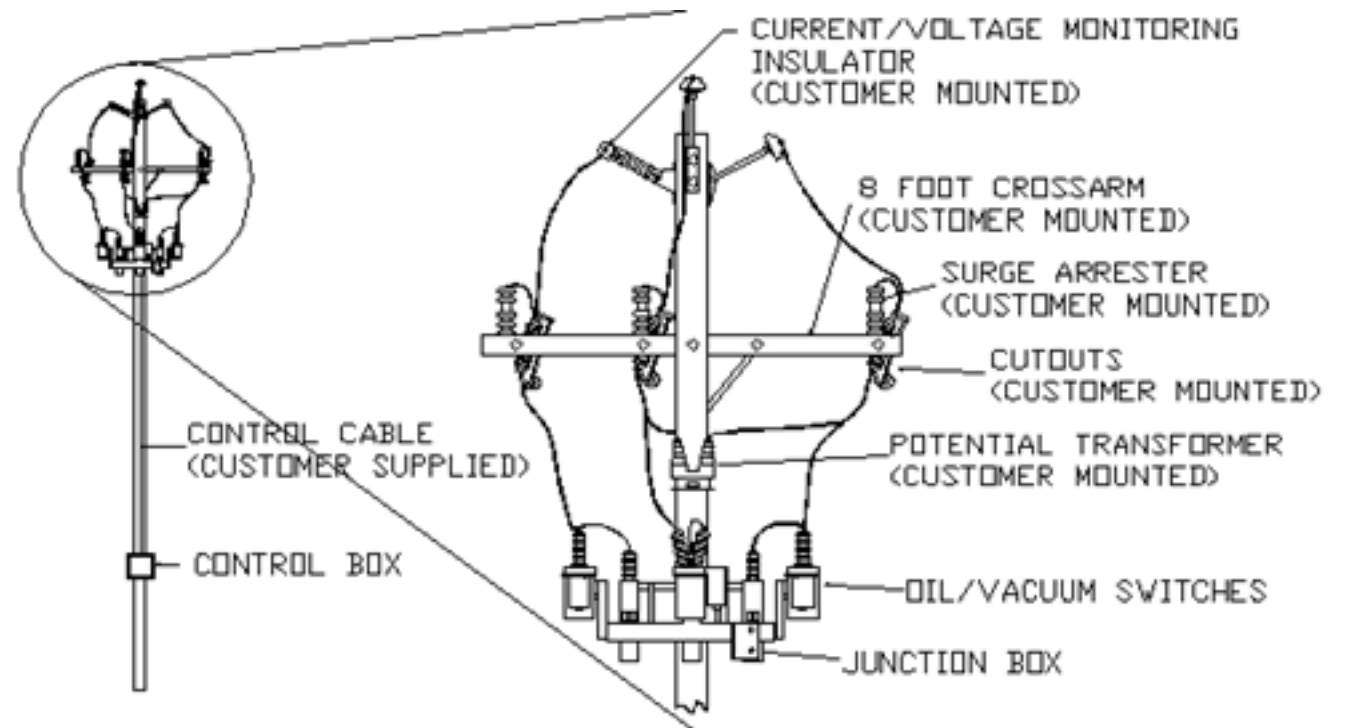

# HUBBELL STANDARD CAPACITOR BANKS - COMPONENTS



TRINETICS CAPACITORS



TRINETICS CAPACITOR FRAME



TRINETICS CAPACITOR SWITCHES



HUBBELL CUTOUTS & FUSES



HUBBELL ARRESTERS



HUBBELL LINE POST SENSORS

## Cap Bank Assemblies

1. Capacitor banks are normally ordered with a certain primary voltage and KVAR rating.
2. They normally come mounted in a rack with the motor or vacuum operated switches, fuses and cutouts, transformer and control, and possibly line post sensors and a complete package.
3. Cap Banks are rated 3-phase so a 600 KVAR cap banks has 200 Kvar per-phase.
4. Cap Banks inject reactive current. A 600 KVAR cap bank connect phase to ground will inject 28 amps per phase.

Hubbell Offers **EXPRESS CAPACITORS BANKS.**



Medium Voltage  
Pole Mount SmartBank™



Medium Voltage  
Ped Mount SmartBank™

# Hubbell Express Bank Package



# Capacitors



## Trinetics® Medium Voltage Shunt Capacitors

- Shunt capacitors – for mv cap banks.
- Two bushings (or) single bushing.
- 95, 110, 125 and 150 kV Bil ratings.
- 50, 100, 150, 200, 300 & 400 kVar standard sizes:
  - 500 kVar and 600 kVar available upon request.
- IEEE 18 and IEC 60871-1 compliant.



# Trinetics® Medium Voltage Shunt Capacitors



- Shunt capacitors – for mv cap banks.
- Two bushings (or) single bushing.
- 95, 110, 125 and 150 kV Bil ratings.
- 50, 100, 150, 200, 300 & 400 kVar standard sizes:
  - 500 kVar and 600 kVar available upon request.
- IEEE 18 and IEC 60871-1 compliant.

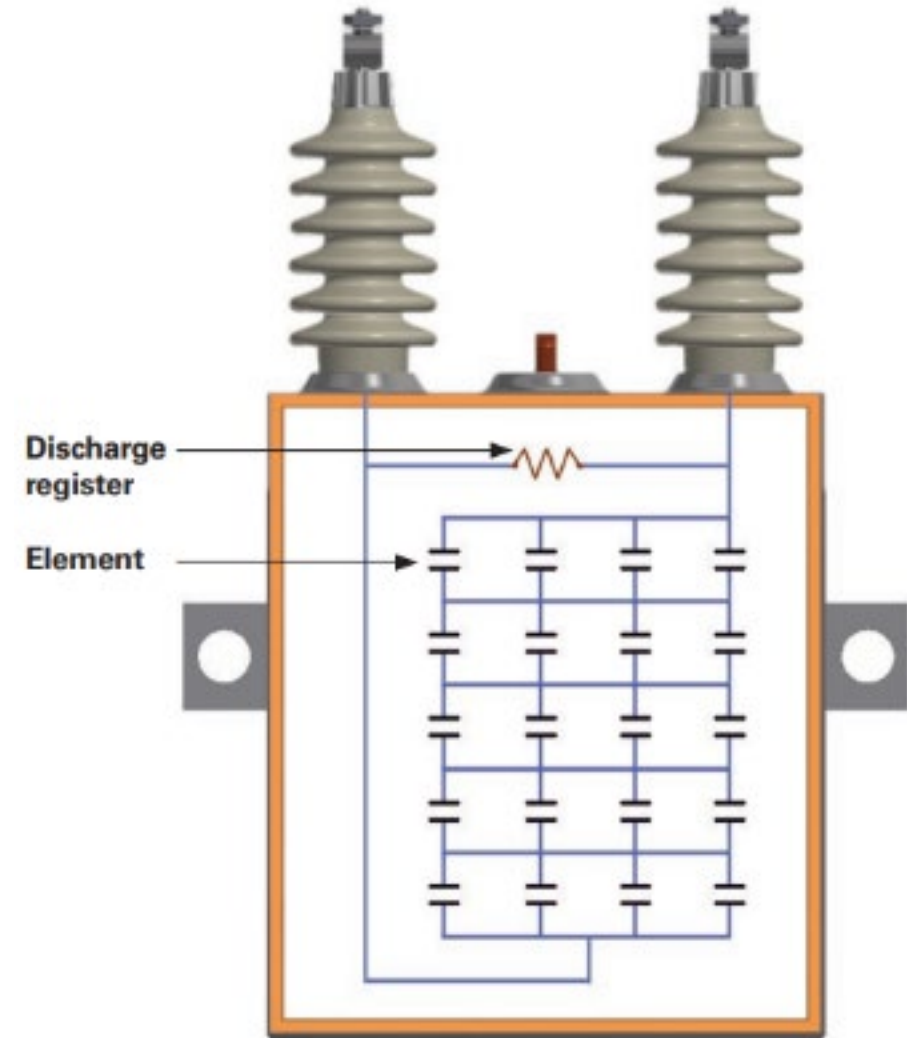

## Standard Duty Capacitors

- Standard-duty are intended to be operated at or below their rated voltage with a continuous overvoltage capability of 110% of rated voltage and to meet the IEEE Std 18™-2002 standard.
- This overvoltage capability is to allow the capacitor to withstand bank and system contingencies such as bank unbalance and system voltages higher than the rated maximum continuous operating voltage.
- Standard-duty ratings:
  - 110% continuous rms overvoltage capability.
  - 10 kA fault handling capability.
  - Standard temperature rating - (-40 to +55) °C.

## Heavy-Duty Capacitors

- Heavy-duty designs meet or exceed IEEE Std C18™-2012 standards. Heavy-duty capacitors are designed for applications where higher reliability is desired.
- The Heavy-duty capacitor is more resistant to the effects of higher transients, harmonics, and voltage excursions than the standard-duty capacitor.
- This overvoltage capability is to allow the capacitor to withstand bank and system contingencies such as bank unbalance and system voltages higher than the rated maximum continuous operating voltage.
- Heavy-duty ratings:
  - 125% (up from 110%) continuous rms overvoltage capability.
  - 135% peak overvoltage capability.

## Extreme-Duty Capacitors

- Extreme-duty capacitors are designed to exceed the IEEE Std C18™-2012 standard.
- These capacitors are designed for the most extreme harmonic environments and are the perfect choice for application on systems with unknown contingencies (Ex: Industrial applications).
- Extreme-duty ratings:
  - 125% continuous rms overvoltage capability.
  - 135% peak overvoltage capability.
  - Tank rupture curve defined through 15 kA.

# Capacitors - Tank Rupture Curves for Fusing

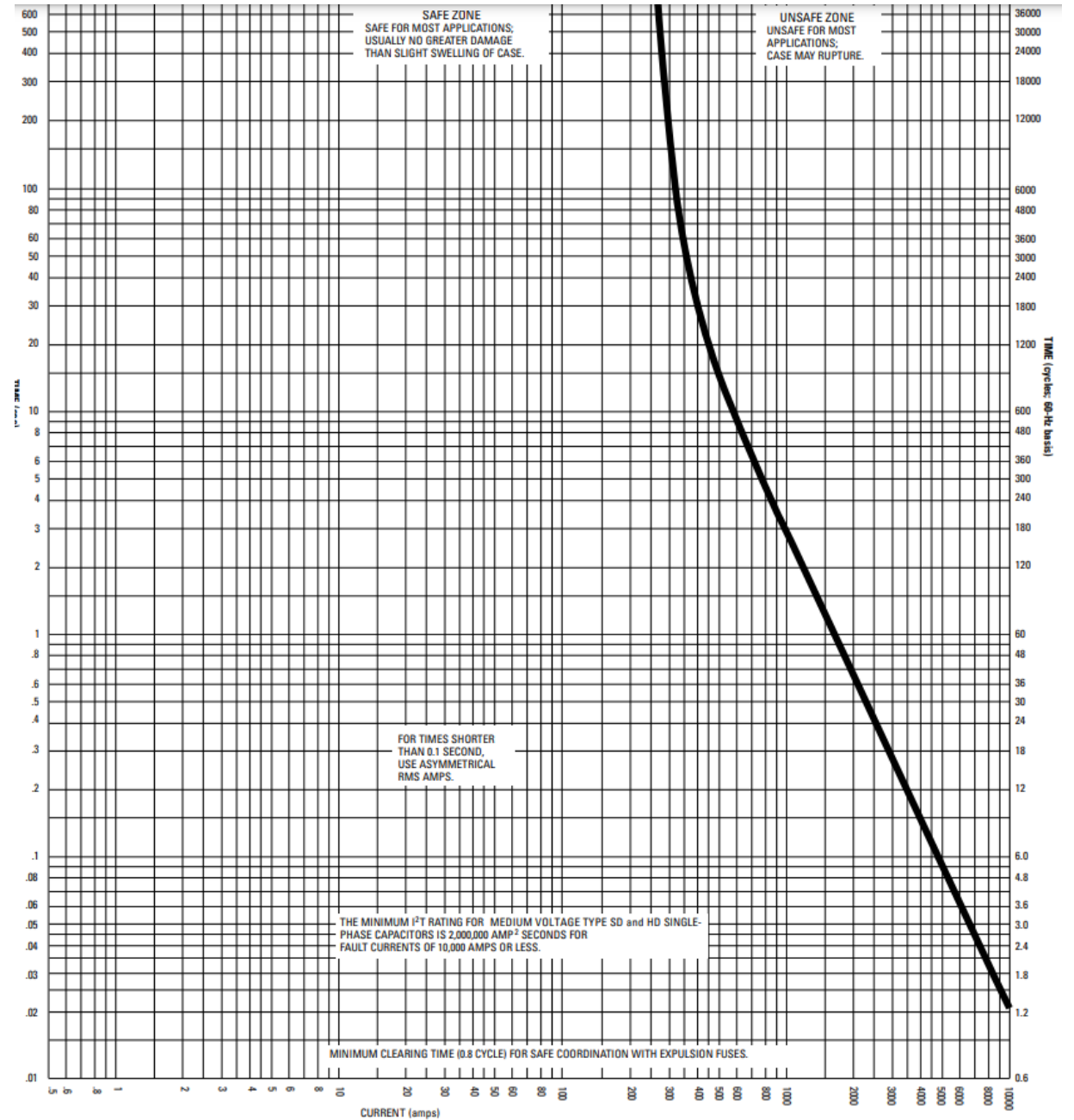

## Cap Bank Components - Switches

1. There are basically two types of switches:
  - a. Motor-Operated – These switches draw less current when operating (typically 1-2 amps) but can take from 5-15 seconds to transition from one state to the other.
  - b. Solenoid-Operated – These switches draw 8-10 amps typically when operating but are very fast, typically changing state within 100-200 msec.
2. Three types of media available : Vacuum , Oil, Vacuum in Oil.

# CAPACITOR SWITCHES – PRODUCT RANGE

## TYPES OF CAPACITOR SWITCHES

### SMARTCLOSE® - SYNCHRONOUS ZERO-CLOSE SWITCH

- Trinetics SmartClose - Highest performance switch in the industry
- Synchronous Zero-Voltage Close Technology
- Primary decision factor: Sensitive Loads & High accuracy

### ULTRAVAC® - SOLID DIELECTRIC VACUUM SWITCH

- Trinetics UltraVac is a market-leading design
- Maintenance-free, long-life, highest performance
- Primary Decision factor: Life cycle + environmental

### VS – VACUUM UNDER OIL CAPACITOR SWITCH

- Mid-level performance
- No competitors in this space
- Primary decision factor: Price + Life cycle

### CSD – OIL CAPACITOR SWITCH

- Legacy product
- Price is primary decision factor
- Primary decision factor: Price

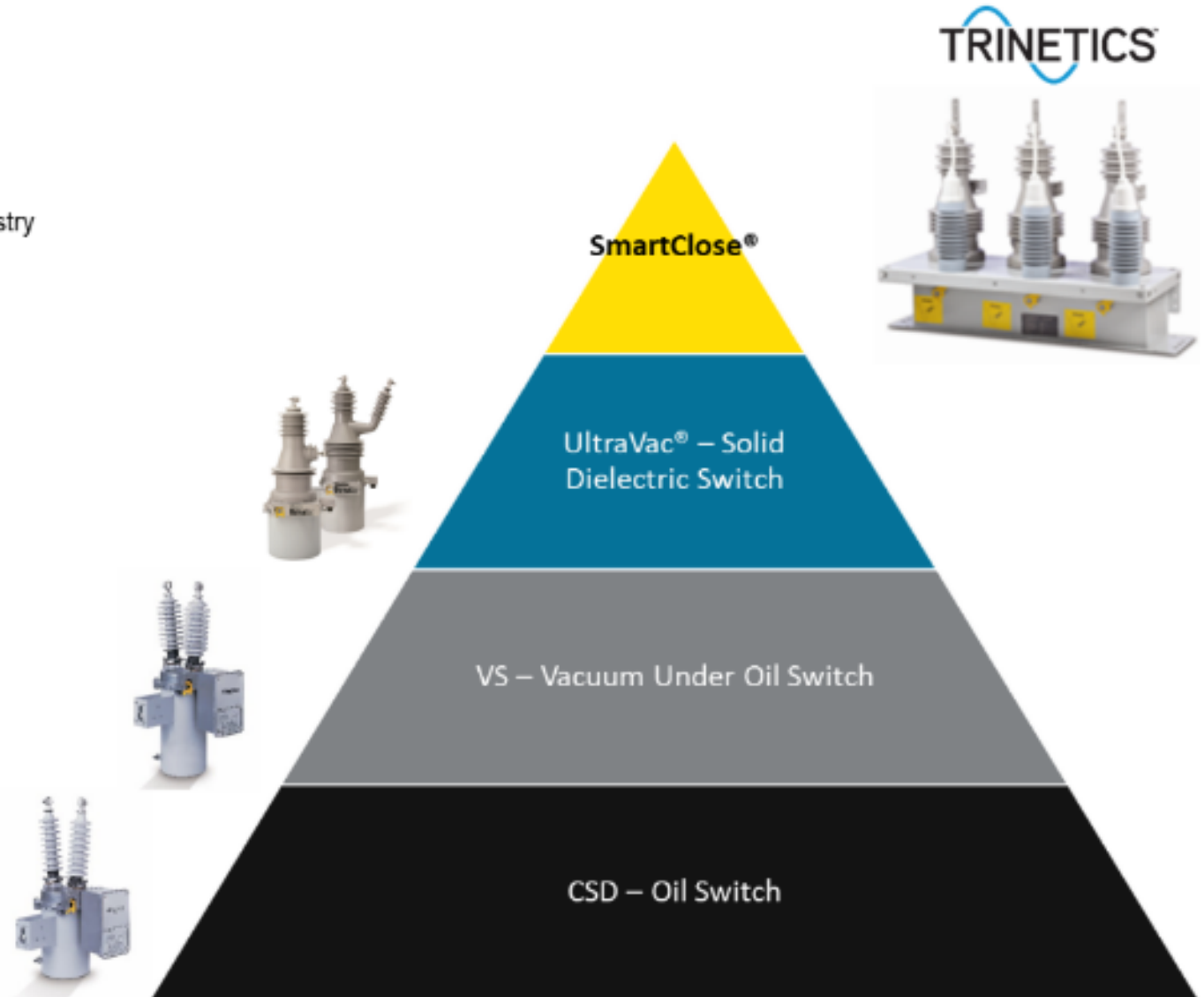

# TRINETICS® CSD Oil Capacitor Switches



- Most economical capacitor switch and legacy design.
- 15 kV through 20 kV; 95 kV Bil to 125 kV Bil.
- Current rating – 200 A (15 kV), 90 A (20 kV).
- Motor-operated switch.
- Motor current rating 3 amps, operating time of 2 to 4 secs.
- 2,000 operations without maintenance.

## NOTES:

- The manual handle is also a position indicator for the switch contacts.
- Electrical operation – 120 V, 50/60 Hz standard; 240 V optional.
- Manual operation – provides manual override when control power is not available.



## TRINETICS® - VS Vacuum Under Oil Switches



- Unique in its class - the only vacuum under oil switch.
- Economical entry into high performance vacuum switching.
- 10,000 operations without maintenance.
- Available 15 kV through 24 kV, 200 A rated.
- Bil ratings: 95 kV – 125 kV.
- Motor-operated vacuum capacitor switch.

### NOTE:

- The manual handle is also a position indicator for the switch contacts.
- Electrical operation – 120 V, 50/60 Hz standard; 240 V optional.
- Manual operation – provides manual override when control power is not available.



# TRINETICS® - ULTRAVAC Solid Dielectric Switch



- Maintenance-free capacitor switch.
- Motor (or) solenoid-operating options.
- 30,000 (motor) and 50,000 operations (solenoid).
- For 15, 25, and 35 kV – 200 A rating.
- Bil ratings: 95 kV, 125 kV, (or) 150 kV.

## NOTE:

- The manual handle is also a position indicator for the switch contacts.
- Electrical operation:
  - Motor: 120 V AC or 240 V AC.
  - Solenoid: 120 V AC, 240 V AC, or 125 V DC.
- Manual operation – provides manual override when control power is not available.



UltraVac Standard

# TRINETICS® - ULTRAVAC Solenoid-Operated



- Single solenoid operator.
- Manual handle (unique open/close operation).
- C2 re-strike free rating.

Switch type	Insulation / Interruption	Operations*
UltraVac	Solid / Vacuum	50,000 Best

### Limits for Proper Operation:

- 10 ft control cable, #14 AWG min.
- 35 ft control cable, #12 AWG min.
- CPT with Low Z, 1.0 kVA min.
- CPT with Standard Z, 1.5 kVA min.



UltraVac Standard

# MOTOR OPERATED (OR) SOLENOID OPERATED?



Type	Feature	Advantage
Motor	Low Current	<ul style="list-style-type: none"> <li>Compatible with small gauge control wire</li> <li>Transformers can be on adjacent pole</li> <li>Large legacy base for MRO sales</li> </ul>
Solenoid	Fast Operation	<ul style="list-style-type: none"> <li>More suitable for self-healing networks</li> <li>C2 re-strike free rating</li> <li>More interchangeable with any competitor vacuum switch</li> </ul>



Solenoid



Motor

Key Feature	Motor	Solenoid
Speed	2.0s to 4.0s	0.1s
Operating Current for 120Vac	3A	9A

Restrikes cause cascading overvoltages that can lead to:  
 Ruptured capacitor cans, Blown Fuses, Failed Arrestors,  
 External equipment flashovers, and contact wear that may  
 lead to interrupter dielectric failures.

## Cap Bank Components - Switches

1. Zero crossing switches/controls:
  - a. Capacitor Banks normally have a 5-minute block on closing the bank after it is open. This is to allow a bleeding resistor to dissipate the stored energy of the capacitor. If the capacitor is closed with a stored voltage it can create up to 2 times voltage and create high voltage issues Device equipped internally with a charge booster circuit to take care of charging/discharging of capacitors as per need.
  - b. This can limit the applications (DER) for regulating voltage with cap banks.
  - c. The zero crossing switch allows the capacitor to be closed at any time because it will close it at zero crossing of the voltage.
  - d. This also reduces PQ impacts of closing in a larger cap bank.
  - e. Closes one capacitor (close solenoid) at a time (with delay as set in the UI).
  - f. Mitigates voltage transients due to DER irregularities.

# Hubbell Zero Close Vacuum Capacitor Switch

1. No more 5 minute reclose delay.
2. Should be required for circuits with PV.

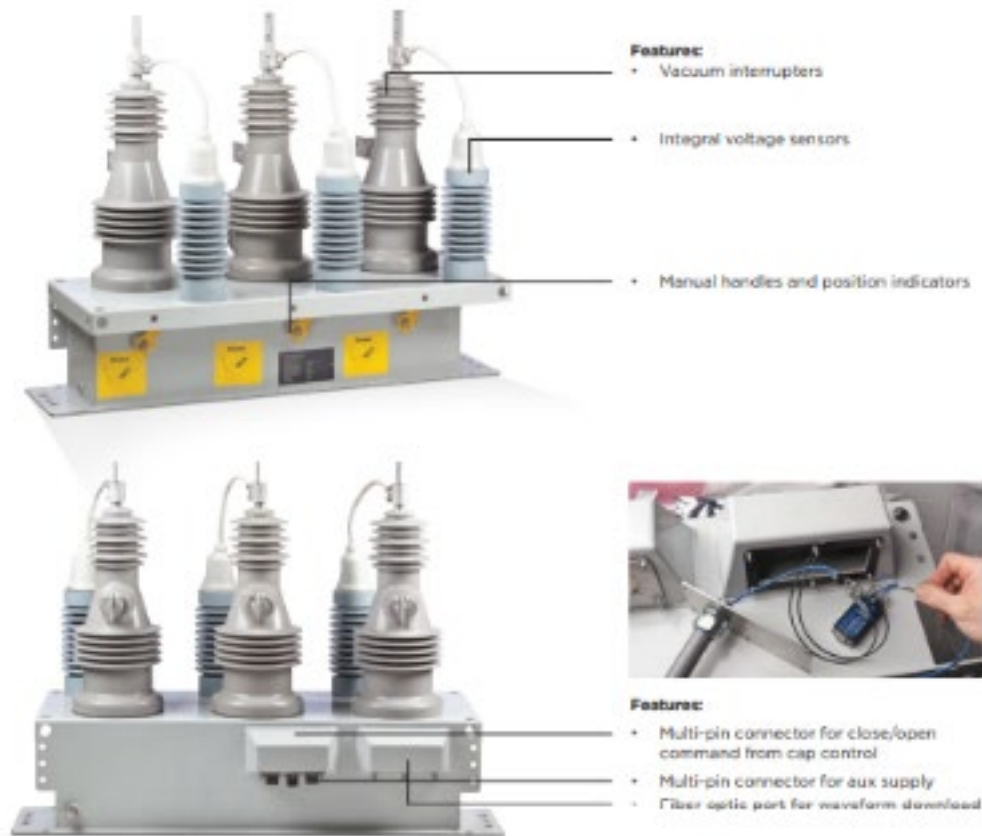

SmartClose Specifications	15kV	25kV
Rated Maximum Voltage, Phase to Phase, for Ungrounded Banks, kV, RMS	15.5	27.6
Impulse Withstand Voltage, kV, B.I.L.	110	125
Terminal-to-Ground Creep Distance, inches(mm)	18(457)	18(457)
Terminal-to-Terminal Creep Distance, inches(mm)	19(482)	19(482)
Low Frequency Insulation Level Withstand		
1 Minute Dry, kV	60	70
1 Minute Wet, kV	50	60
Continuous Current, Amps	200/400	200/400
Capacitive Switching Current, Amps	200/400	200/400
Fault Making Current Rating, Amps, Peak Assymetrical	32500	32500
Short Time Current Rating, 1 second, Amps, RMS	12500	12500
High Frequency Transient Making Current, Amps, Peak, at 6kHz	16000	16000
Operating Voltage, VAC 50/60Hz, +/-15%	120	120
Operating Current Rating, Amps	8	8
Close Command Input Voltage pulse (>90mS), AC or DC	40 to 150	40 to 150
Open Command Input Voltage pulse (>90mS), AC or DC	40 to 150	40 to 150
Environmental Operating Temperature, °C, Standard	-30 to +65	-30 to +65
Environmental Operating Temperature, °C, Optional	-50 to +65	-50 to +65
Maintenance Free Operations	30000	30000
Oil Free, Solid Dielectric	Yes	Yes
Restrike Performance, 0 restrikes	C2	C2
ANSI Test Standard	C37.66-2005	C37.66-2005
Weight, Lbs., (kg)	195(88)	195(88)

# Hubbell Express Bank Package

**SURGE ARRESTORS**  
IEC 5kA, 10kA Class 1 & 2, Distribution Medium & High Surge Arresters  
IEEE Normal Duty, Heavy Duty, and Riser Pole Surge Arresters

**CAPACITORS**

**CAPACITOR SWITCHES**

- Oil-type
- Vacuum Under Oil
- Solid Dielectric Vacuum
- Synchronous Zero Close

**SENSORS**

**BECKWITH CAPACITOR BANK CONTROLS**  
Universal Capacitor Bank Control solution for Advanced Distribution Grid Optimization Applications including Volt/VAr Optimization (VVO), Conservation Voltage Reduction (CVR), and Power Quality Monitoring.

- M-6280A Single Phase Sensing Capacitor Bank Control
- M-6283A Three Phase Sensing Capacitor Bank Control

**INTERFACE OPTIONS**

**Direct Breakout Cable**  
Sensors, switches, and AC power wired directly to control using connectorized cables.

**Hybrid**  
Sensors connect to control via direct breakout cable. Switches and AC power use a junction box that connects to the control using a connectorized cable.

**Junction Box**  
Sensors, switches, and AC power use a junction box that connects to the control using a connectorized cable.

**CUTOUTS & FUSES**

- SmartBanks include wildlife mitigation solutions.

### CATALOG ORDERING SYSTEM

**DIGITS =** 1-2 3-4 5-6 7 8 9 10 11 12 13 14-15 16 17 18

**PRELIMINARY MODEL NUMBER =** SB XX X X X X X X X X XX X X X

*Final model number will be indicated in the official quote from Beckwith*

Configure online at [www.SmartBankSolutions.com](http://www.SmartBankSolutions.com)

DIGITS 5-6	
SYSTEM VOLTAGE & BIL RATING	
00	12470V (L-L) / 7200V (L-G), 50kV BIL
02	24940V (L-L) / 14400V (L-G), 125kV BIL
XX	Other Voltage (L-L) Please specify: _____ Other kV BIL Please specify: _____

DIGIT 8	
CAPACITOR BUSHINGS*	
X	None
1	1 Capacitor/Phase, 2 Bushings/Capacitor
2	2 Capacitor/Phase, 2 Bushings/Capacitor
3	3 Capacitor/Phase, 2 Bushings/Capacitor
4	1 Capacitor/Phase, 1 Bushing/Capacitor
5	2 Capacitor/Phase, 1 Bushing/Capacitor
6	3 Capacitor/Phase, 1 Bushing/Capacitor

DIGIT 10	
HUBBELL ARRESTERS	
Y	Yes (Hubbell selected based on bank voltage)
X	No
Z	User Specified, Please specify: _____

DIGIT 13	
REACTORS	
X	No (Standard Option)
Y	Yes (Hubbell selected based on bank voltage)
Z	Customer Supplied

DIGIT 11	
CONTROL POWER TRANSFORMER	
Y	Yes (Hubbell selected based on bank voltage)
X	No (Customer Supplied)
Z	User Specified, Please specify: _____

DIGIT 14-15	
CABLE LENGTH TO CONTROL	
XX	No Cable
15	15 Feet
30	30 Feet
40	40 Feet

**SB**

DIGIT 3-4	
TOTAL CAPACITOR BANK SIZE (KVARs)	
01	50 KVAR
03	300 KVAR
04	450 KVAR
06	600 KVAR
09	900 KVAR
12	1200 KVAR
XX	Other KVAR, Please specify: _____

DIGIT 7	
DISTRIBUTION SYSTEM CONNECTION TYPE	
Y	Grounded Wye
D	Delta

DIGIT 9	
CAPACITOR SWITCH TYPE	
C	CSD Oil Capacitor Switches (3)
V	V5 Vacuum Under Oil Capacitor Switches (3)
S	UltraVac - Solid Dielectric Switches, Solenoid (3)
M	UltraVac - Solid Dielectric Switches, Motor (3)
A	SmartClose - Three Phase Synchronous Zero Close Capacitor Switch (1) (602k)
B	SmartClose - Three Phase Synchronous Zero Close Capacitor Switch (1) (600k)
Z	Other Please specify: _____

DIGIT 12	
INTERFACE TYPE	
D	DIRECT BREAKOUT CABLE Sensors, switches and ac power wired directly to control using connectorized cables.
H	HYBRID Sensors connect to control via direct breakout cable. Switches and ac power use a junction box that connects to the control using a connectorized cable.
J	JUNCTION BOX Sensors, switches and power connect to a junction box. Junction box connects to control using connectorized cables.

DIGIT 16	
CAPACITOR BANK CONTROLLER	
X	No Control
4	Beckwith M-6280A Single Phase Sensing Control
6	Beckwith M-6283A Three Phase Sensing Control (Requires three sensors)
C	Custom Configured Control. Specify: _____

DIGIT 18	
CUSTOMER REQUIREMENTS	
0	None
X	Customer Specific Requirements (CSR# _____)

DIGIT 17	
SENSOR OPTIONS	
X	No Sensors (Customer Supplied)
1	Hubbell CMI Line Post Current Sensor (1)
2	Hubbell CMI Line Post Current Sensor (1) & Neutral Current Sensor (3)
3	Hubbell CVMi Multicore Current & Voltage Sensor (1)
4	Hubbell CVMi Multicore Current & Voltage Sensor (1) & Neutral Current Sensor (1)
5	Hubbell CMI Line Post Current Sensor (3)
6	Hubbell CMI Line Post Current Sensor (3) & Neutral Current Sensor (1)
7	Hubbell CVMi Multicore Current & Voltage Sensor (3)
8	Hubbell CVMi Multicore Current & Voltage Sensor (3) & Neutral Current Sensor (1)
A	Lindsay CVMi Line Post Current Sensor (1)

# Capacitor Control Modes

## Cap Bank Control Modes

1. Traditionally cap banks were switched either with Time-of-Day or temperature.
2. Recently most cap banks are controlled by:
  1. Voltage.
  2. VARs.
  3. PF.
  4. Current.
3. Some control modes require no sensors (time-of-day) while others require voltage, current, or temperature, or a combination.

# Capacitor Sensors

## Cap Bank Sensors – Gang Voltage

1. If a single voltage is required (gang-operated voltage mode) the distribution transformer is typically used
2. If multiple cap banks are installed on the same feeder the distribution transformer for each location should be fed from a different phase incase there is a phase imbalance on the voltages

# Voltage Control Mode

## Local Voltage Control

### Auto(Matic) Voltage Control Mode

- Classic Mode
- Open in at Upper End Voltage,
- Close in at Lower End Voltage

Example -

Above 123 V, Time Delay is in effect, once met Control opens bank.

Below 117 V, Time Delay is in effect, once met Control closed bank.

Time For Event is either

Definite Time.

Standard linear scale

30 Sec at, or above Voltage,

means 30 Sec Regardless

OR Inverse Time – Next Slide

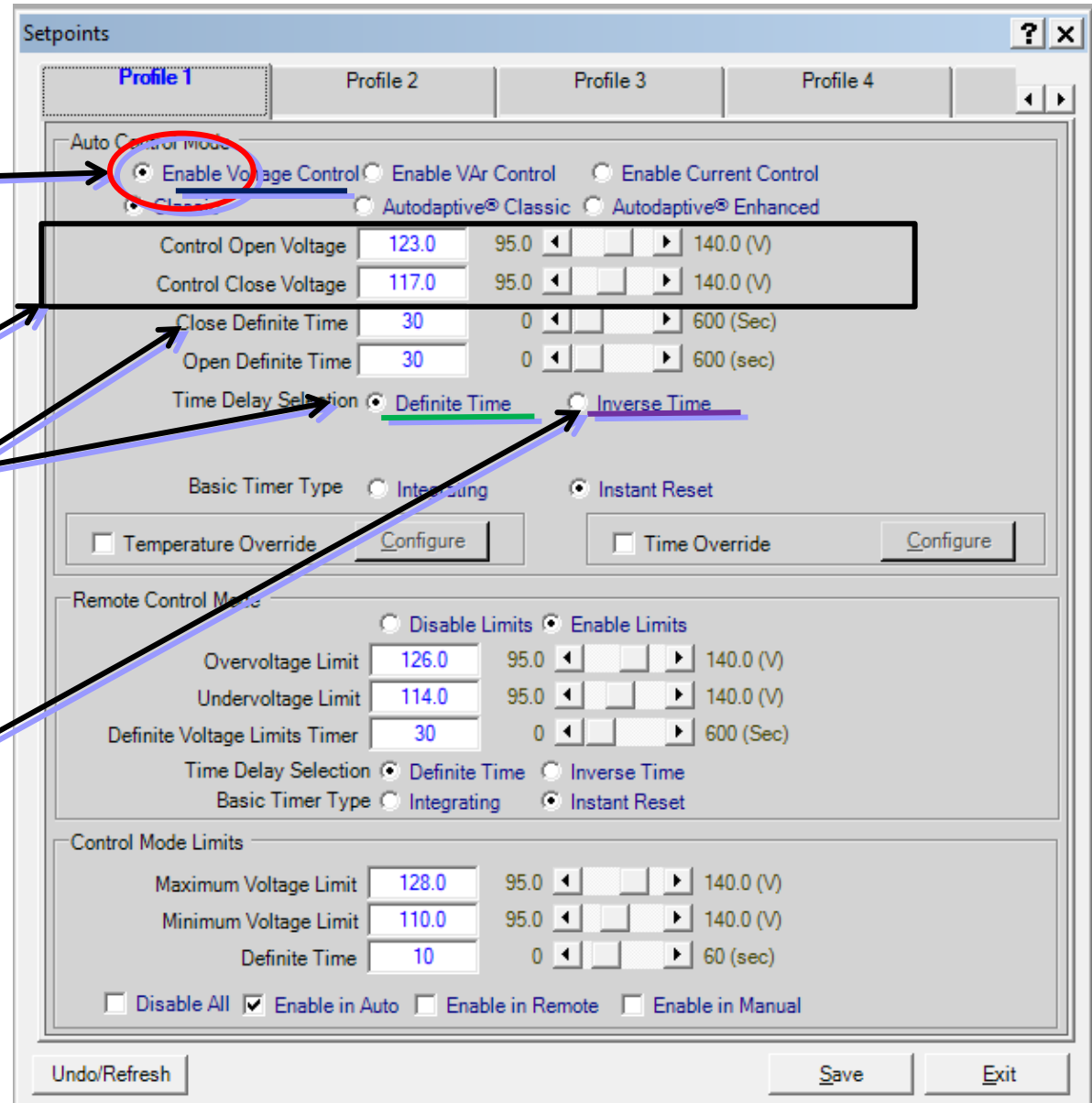

# Voltage Control Mode

## Local Voltage Control

- Main Screen for Control Capacitor Bank Open/Close conditions and criteria.
- For Voltage Controls they need to be coordinated with the regulator/LTC settings.
- The Open and Close settings must be within the band settings of the regulator/LTC.
- Time delays should be shorter on the capacitor banks than the regulators/LTC.
- Cap banks furthest from the source should have the shortest close and longest open time delay.
- Cap banks closest to the source should have the longest close and shortest open time delay.
- Have the Delta Voltage of the cap bank be less than 66% of the bandwidth of the LTC/regulator controls.

**Setpoints**

Profile 1 | Profile 2 | Profile 3 | Profile 4

**Auto Control Mode**

Enable Voltage Control
  Enable VAr Control
  Enable Current Control

Classic
  Autodaptive® Classic
  Autodaptive® Enhanced

Control Open Voltage:  95.0 ◀ ▶ 140.0 (V)

Control Close Voltage:  95.0 ◀ ▶ 140.0 (V)

Close Definite Time:  0 ◀ ▶ 600 (Sec)

Open Definite Time:  0 ◀ ▶ 600 (sec)

Time Delay Selection:  Definite Time  Inverse Time

Basic Timer Type:  Integrating  Instant Reset

Temperature Override 
 Time Override

**Remote Control Mode**

Disable Limits
  Enable Limits

Overvoltage Limit:  95.0 ◀ ▶ 140.0 (V)

Undervoltage Limit:  95.0 ◀ ▶ 140.0 (V)

Definite Voltage Limits Timer:  0 ◀ ▶ 600 (Sec)

Time Delay Selection:  Definite Time  Inverse Time

Basic Timer Type:  Integrating  Instant Reset

**Control Mode Limits**

Maximum Voltage Limit:  95.0 ◀ ▶ 140.0 (V)

Minimum Voltage Limit:  95.0 ◀ ▶ 140.0 (V)

Definite Time:  0 ◀ ▶ 60 (sec)

Disable All
  Enable in Auto
  Enable in Remote
  Enable in Manual

# Voltage Control Mode

## Grid Coordination

- Cap Banks with coordinated time delays.
- If regulator or LTCs are upstream of the cap banks their time delays should be longer than the cap bank time delays.
- The Cap Bank Close Voltage should be set higher than regulator low bank to allow it to close before the regulator taps. Likewise, the Open should be lower than the regulator upper band to allow a cap bank to open before the regulator taps

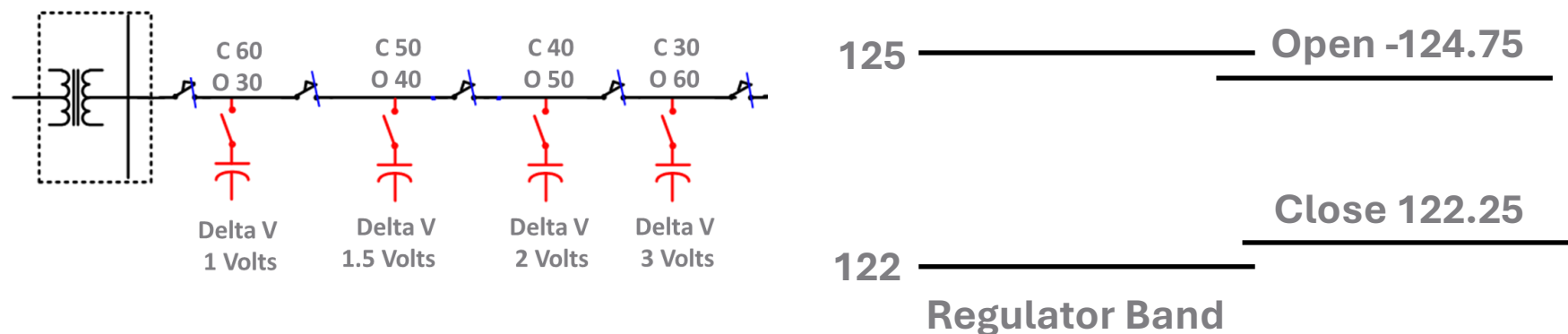

# Voltage Control Mode

## Grid Coordination – Delta V

- The Delta V is the voltage changed caused at the cap bank when it operates.
- Need to keep the Delta V smaller than the bandwidth of the LTC and regulators (in this case the Delta V needs to be less than 2.5),
- Time Delays of cap banks should be smaller than the upstream LTC or regulators.

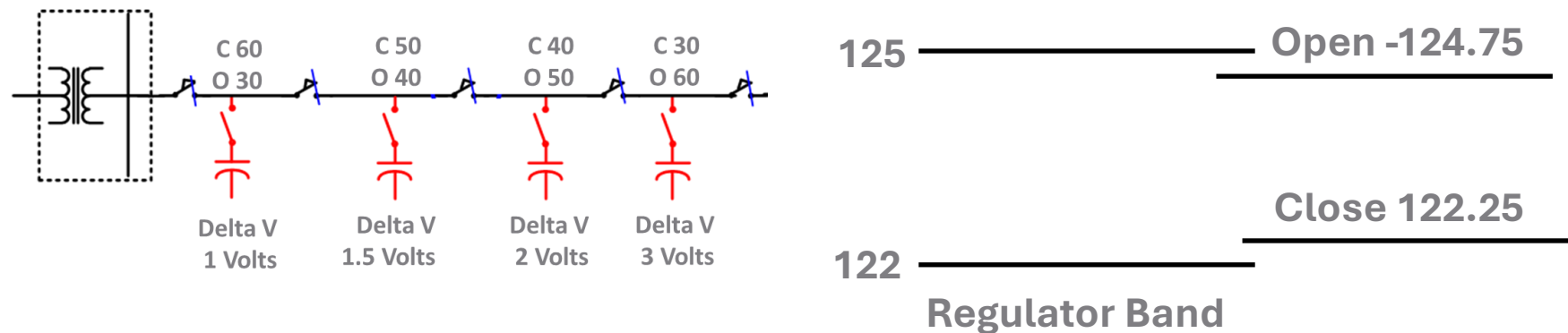

# Voltage Control Mode

## Grid Coordination – Hunting

- If the Delta V is greater than the Voltage difference between the Open and Close Voltages hunting will occur.
- For the example below ( $124.75 - 122.25 = 2.5$  so if the Delta V is 2.5 or greater the cap bank will keep switching between open and close operations ).

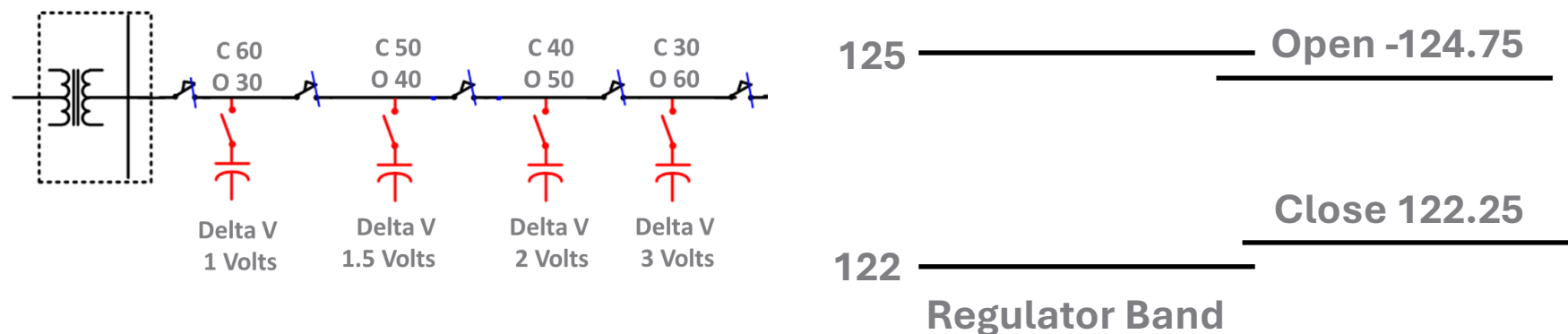

## Hubbell Line Post Sensors

### Cap Bank Sensors – Gang Current/Var/pF

1. In gang operated mode a line post sensor will be required. A combination line post sensor can be used or a current linepost sensor can be with the distribution transformer. In this case the current LPS needs to installed on the same phase as the distribution transformer.
2. If multiple cap banks are installed on the same feeder the distribution transformer for each location should be fed from a different phase incase there is a phase imbalance on the voltages.

# Hubbell Line Post Sensors

RATINGS AND SPECIFICATIONS									
Product	Current Sensor			Voltage Sensor			Current and Voltage Sensor		
Measurement Output	600A:10V			10000:1			C - 600A:10V		
	1000A:10V			1400:1	2200:1	3300:1	V - 1400:1	V - 2200:1	V - 3300:1
							V - 10000:1	V - 10000:1	V - 10000:1
Nominal Rating (kV)	15	27	35	15	27	35	15	27	35
Rated Line to Ground Voltage (kV)	8.66	15.59	20.21	8.66	15.59	20.21	8.66	15.59	20.21
Positive Impulse Rating or BIL (kV)	110	150	170	110	150	170	110	150	170
<b>Withstand Rating (kV)</b>									
60Hz Dry Withstand	34	40	50	34	40	50	34	40	50
60Hz Wet Withstand	34	40	50	34	40	50	34	40	50
Leakage Distance (Inches)	23.2	35.4	35.4	23.2	35.4	35.4	23.2	35.4	35.4
Dry Arcing Distance (Inches)	9.7	13.2	13.2	9.7	13.2	13.2	9.7	13.2	13.2
Overall Height (Inches)	12.3	15.8	15.8	12.3	15.8	15.8	12.3	15.8	15.8
Partial Discharge Test Voltages (kV)	11	20	27.4	11	20	27.4	11	20	27.4
Maximum Pico Coulomb	10 pC or less at PD Test Voltage								
Weight (lbs)	17	21	21	17	21	21	17	21	21
Ultimate Cantilever Strength* (lbs)	2800	2800	2800	2800	2800	2800	2800	2800	2800
Temperature Range	65° C to -45° C								
<b>Current Signal Output (CMI and CVMI)</b>									
Ratio	600A:10V (or) 1000A:10V								
Output Burden/Load	1 Meg Ohm or Greater								
Accuracy	± 1%								
Phase Shift	0° nominal, ± 1.5°								
Sensors are calibrated at 300A for best accuracy across load current range of 0-600A.									
<b>Voltage Signal Output (VMI and CVMI)</b>									
Ratio	10000:1 / 1400:1 / 2200:1 / 3300:1								
Output Burden/Load	1 Meg Ohm or Greater								
Accuracy	± 1%								
Phase Shift	0° nominal, ± 1°								



# Hubbell Line Post Sensors

## Step 1: Sensor Mounting & Orientation

The sensor is primarily intended for vertical or horizontal tangent conductor mounting and is not intended for use to dead-end the primary conductor. When mounting the sensor, the molded-in "H1" designation on the side of the sensor must be toward the source of power or feeder source for correct signal polarity. If reversed, the current output signal will be 180° out of phase.

The line post sensor can be mounted either on an iron pin or on a metal cross arm or other apparatus surface. The mounting inserts in the bottom of the sensor are all electrically connected internal to the product and must be grounded before energizing.

For surface or equipment mounting, use the four 1/2"-13 3-inch bolt circle pattern inserts excluding the mounting plate.

For pin mounting, attach the base grounding plate using the flat-head socket cap screws. Mount the sensor on the stud using the 3/4"-10 bolt-hole insert. Both mounting options are threaded to accommodate the use of galvanized hardware. Please note that the 3/4" inch stud for mounting must be ordered separately and is not included along with the sensor.



## Step 2: Sensor Grounding

The line post sensor MUST be grounded before it is energized. The following are 2 different grounding procedures that could be followed to ensure a solid ground connection.

### Standard Grounding Method:

1. Position the grounding plate on the base of the sensor and use the 1/2"-13 flat head socket cap screws to tighten the grounding plate to the 3 inch bolt circle inserts on the base.
2. Install the sensor on center pin on the cross arm using a 3/4" stud.
3. The grounding plate contains a slot for accommodating ground wire diameters from 0.102" [2.8] to 0.322" [8.2].
4. Insert the ground wire through the slot and tighten the grounding screw to secure the grounding wire in position.
5. Connect the grounding jumper to a low resistance pole ground.



# Line Post Sensors

- Line Post Sensors should be mounted between source and cap bank.
- If polarity is correct positive MW and positive MAVr indicate forward power (going from source to load) and Lagging MVAr going from source to load.

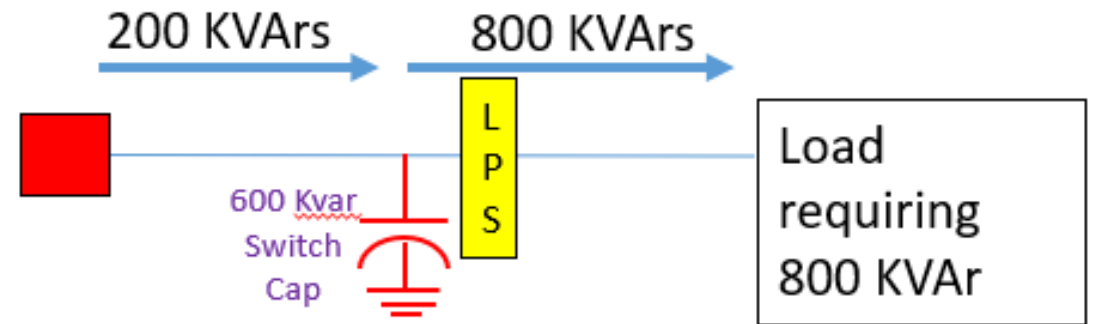
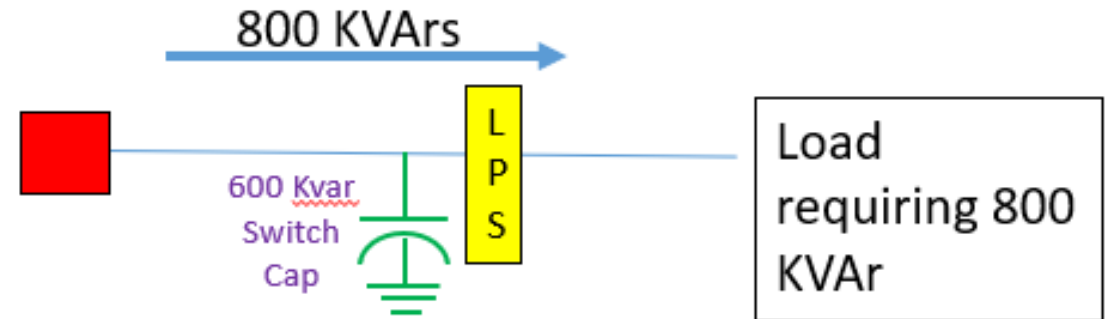
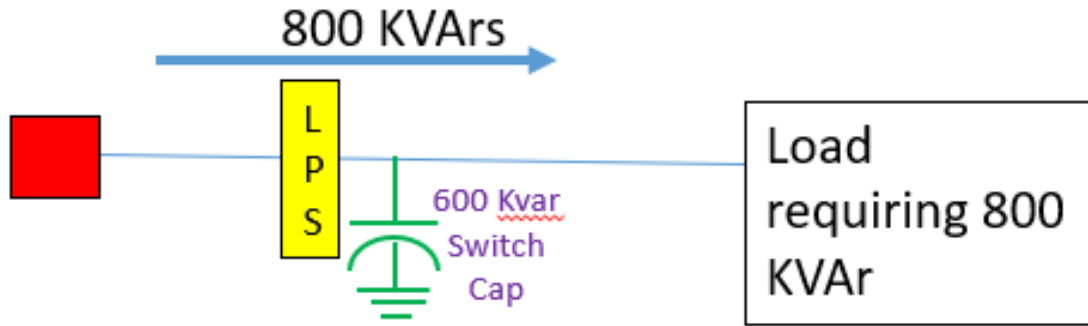

Linepost Sensor mounted on Source Side of Capacitor Bank

Linepost Sensor mounted on Load Side of Capacitor Bank

**Source Side, so substation is on this side**



**Load Side, so end of line is on this side**



# VAR Control Mode

## Local VAR Control

### Auto(Matic) Control Mode

Can be set for 1 of 5 Parameters

- Voltage
- **VAR**
- Current
- Temperature
- Time

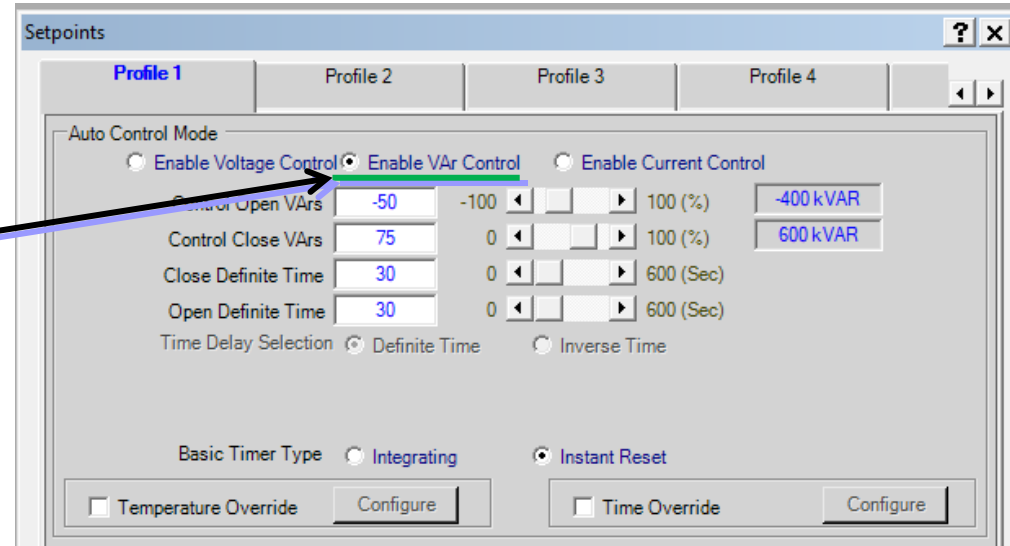

Notes:

- Positive VARS mean Vars into load (delivered from substation) indicating a lagging PF.
- When VARs are lagging to a point where VAR's are required, Cap Bank closes in.
- When Vars are leading more than the Open Var setting the cap bank opens.

Bank Size	1200	
Close KVAR	900	Close when the KVAR exceeds 900 KVAR lagging
Open KVAR	-400	Open when the KVAR exceeds 400 KVAR leading
Spread	1300	
Bank Size	600	
Close KVAR	400	Close when the KVAR exceeds 900 KVAR lagging
Open KVAR	-100	Open when the KVAR exceeds 400 KVAR leading
Spread	500	This will cause hunting

# Current Control Mode

## Local Current Control

### Auto(Matic) Control Mode

Can be set for 1 of 5 Parameters

- Voltage
  - VAR
  - **Current**
  - Temperature
  - Time
- Current can be used as a Trigger condition.
  - High current correlates to onset of inductive loading and capacitors are closed in. Low current corresponds to low loading and capacitor bank opens.

The screenshot shows the 'Setpoints' configuration window for 'Profile 1'. The 'Auto Control Mode' section is active, with 'Enable Current Control' selected. The parameters for current control are highlighted with a black box:

Parameter	Value	Min	Max	Unit
Control Open Current	50	10	600	(A)
Control Close Current	100	10	600	(A)
Close Definite Time	30	0	600	(Sec)
Open Definite Time	30	0	600	(sec)

Other settings in the window include:

- Basic Timer Type:  Instant Reset
- Remote Control Mode:  Enable Limits
- Overvoltage Limit: 126.0 (95.0 to 140.0 V)
- Undervoltage Limit: 114.0 (95.0 to 140.0 V)
- Definite Voltage Limits Timer: 30 (0 to 600 Sec)
- Control Mode Limits: Maximum Voltage Limit 128.0, Minimum Voltage Limit 110.0, Definite Time 10 (0 to 60 sec)

Buttons at the bottom include 'Undo/Refresh', 'Save', and 'Exit'.

# Neutral Unbalance Current Detection

## Neutral Current Sensor

- If the cap bank is operated in gang-operated mode and all three phases stay in sync there will be no ground current.
- If a fuse blows, switch on a single phase fails to operate, or capacitor cans have failed, neutral current will be present as some phases will have current coming out of the capacitor bank when other(s) don't.
- Neutral Current has to be coordinated with upstream reclosers if they are performing single-phase trip/lockout or it can create false neutral current alarms.

# Neutral Unbalance Current Detection

## Neutral Current Sensor

- The neutral unbalance input to the control can come from any one of the following:
  - A fixed ratio donut type current transformer (CT) with a 200 mA secondary.
  - A split core CT with a 200 mA secondary.
  - A CT with a burden resistor across the secondary which develops a 0 to 10 volt representative signal.
  - A Fisher Pierce 1301 Current Sensor.

Open/Close state of each Phase			Phase angle of $I_N$ with respect to VA
A	B	C	
Open	Open	Open	N/A
Close	Open	Open	$90^\circ \pm 10^\circ$
Open	Close	Open	$-30^\circ \pm 10^\circ$
Open	Open	Close	$210^\circ \pm 10^\circ$
Close	Close	Open	$30^\circ \pm 10^\circ$
Open	Close	Close	$270^\circ \pm 10^\circ$
Close	Open	Close	$150^\circ \pm 10^\circ$
Close	Close	Close	N/A



# Neutral Unbalance Current Detection

- Neutral Unbalance can indicate capacitor failure, pack failure, blown fuses, or stuck switches.
- Retry Operation retries immediately prior operation in case switch did not fully open/close on all three phases.
- Reverse Operation sends the opposite command of the immediately prior operation.

**Bank/Switch Status**

**Bank/Switch Failed Level 2**

Bank/Switch Failed Level 2  1.0  (A)

Level 2  Disable  Enable

Time Delay  10  (Sec)

**Failed Level 2 Prior Operation**

Action Taken  Retry Operation  Reverse Operation and Block  Reset Block

# of Attempts

Block Reset Time Delay  1  (Hours)

**Failed Level 2 No Prior Operation**

Disable  Enable

Open and Lockout Time Delay  1  (mins)

Reset Lockout

Lockout Reset Time Delay  1  (Hours)

**Bank/Switch Failed Level 1**

Bank/Switch Failed Level 1  1.0  (A)

Level 1  Disable  Enable

**Bank Status**

Bank Status Closed  0.10  (A)

Bank Status Open  0.10  (A)

Bank Status  Disable  Enable

Time Delay  10  (Sec)

Action Taken  Retry Operation

Bank Switch Detect  Disable  Enable

Switch Type  52a  52b

Undo/Refresh Save Close

# Local Temperature Override

## Local Temperature Control

- Enabling Temperature Override - Opens up the Temperature Override Configuration Menu.
- Bank Operation can be set for Temperatures between 185 F and -40 F (C).
- In this case, Temperatures above 95 F close the Capacitor Bank, adding VARs to an assumed Inductive Loading condition. (Air conditioning Motor Load).
- Capacitor Bank is Opened with no need of VAR support at lower temperature (70 F).

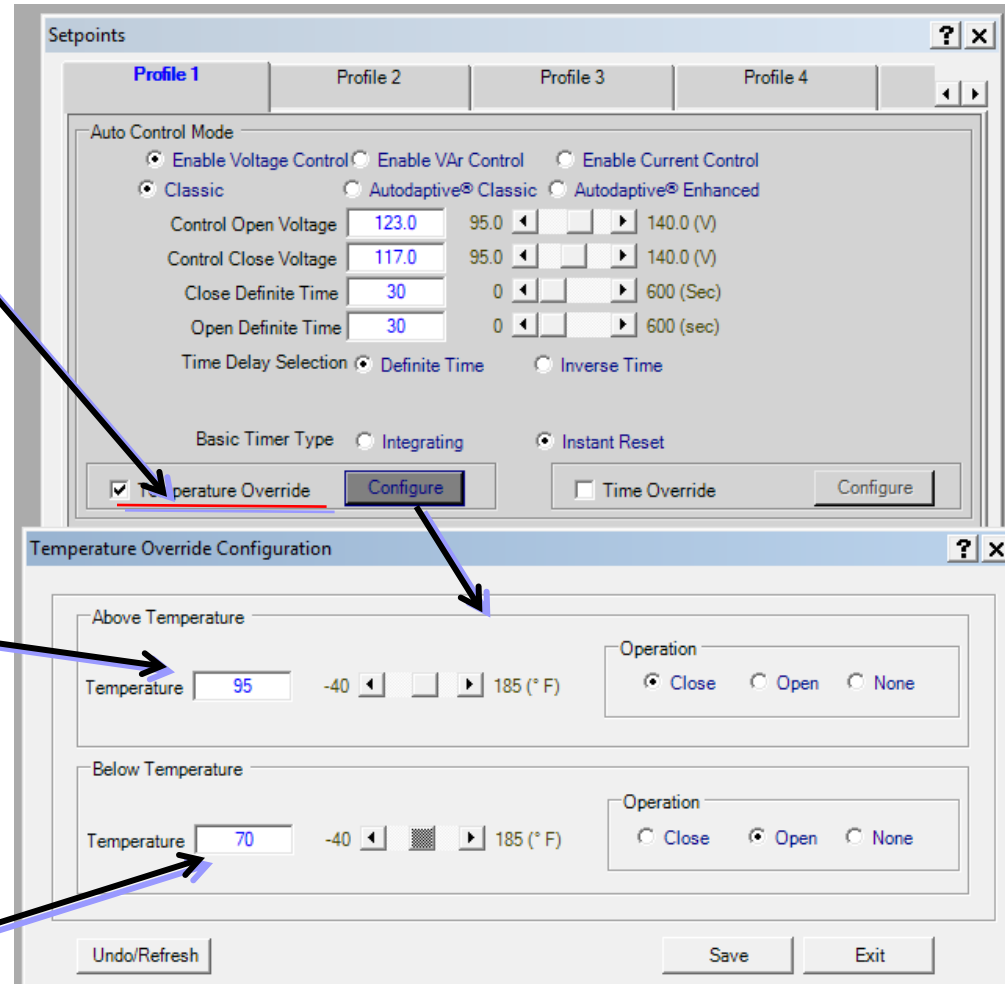

# Local Time Override

## Local Time Control

- Time Override Configure Opens Time Override Configuration menu.
- Conditions are the start of the time operations.
- Parameters:
  - Start Date.
  - End Date.
  - Start Time.
  - End Time (24-hour cycle).
  - Weekly Profile.
  - Condition for Start Time is either Open or Close.

Setpoints

Profile 1 | Profile 2 | Profile 3 | Profile 4

Auto Control Mode

Enable Voltage Control  Enable VAr Control  Enable Current Control

Classic  Autodaptive® Classic  Autodaptive® Enhanced

Control Open Voltage: 123.0 95.0 140.0 (V)

Control Close Voltage: 117.0 95.0 140.0 (V)

Close Definite Time: 30 0 600 (Sec)

Open Definite Time: 30 0 600 (sec)

Time Delay Selection:  Definite Time  Inverse Time

Basic Timer Type:  Integrating  Instant Reset

Temperature Override  Time Override

Time Override Configuration

Bank Operation

Start Date: 1/ 1/2010

Start Time: 10:00:00 AM  Close  Open

End Date: 1/ 2/2010 occurrences: 1

End Time: 6:00:00 PM Duration: 8.0 0.0 24.0 (Hours)

Recurrence Pattern

Daily  Weekly

Sunday  Monday  Tuesday  Wednesday

Thursday  Friday  Saturday

Range of occurrence

No end date  End after

Undo/Refresh Save Exit

# Remote Control Overrides and Blocks

## Remote Control Mode

- This is a secondary safety point for voltage limits. Can be enabled or not.
- Block or Initiate – Block a given command if the result violates a given system parameter. Initiate a command to switch to ultimately return operating parameters to non-violation state.
- Time delay is for initiating.

The screenshot shows the 'Setpoints' configuration window for Profile 1. The 'Remote Control Mode' section is highlighted with a blue arrow pointing from the text 'Can be enabled or not.' in the list above. The interface includes the following sections and settings:

- Auto Control Mode:**
  - Enable Voltage Control (selected), Enable VAr Control, Enable Current Control
  - Classic (selected), Autodaptive® Classic, Autodaptive® Enhanced
  - Control Open Voltage: 123.0 (range 95.0 to 140.0 V)
  - Control Close Voltage: 117.0 (range 95.0 to 140.0 V)
  - Close Definite Time: 30 (range 0 to 600 Sec)
  - Open Definite Time: 30 (range 0 to 600 sec)
  - Time Delay Selection: Definite Time (selected), Inverse Time
  - Basic Timer Type: Integrating, Instant Reset (selected)
  - Temperature Override: [ ] [Configure]
  - Time Override: [ ] [Configure]
- Remote Control Mode:**
  - Disable Limits, Enable Limits (selected)
  - Overvoltage Limit: 126.0 (range 95.0 to 140.0 V)
  - Undervoltage Limit: 114.0 (range 95.0 to 140.0 V)
  - Definite Voltage Limits Timer: 30 (range 0 to 600 Sec)
  - Time Delay Selection: Definite Time (selected), Inverse Time
  - Basic Timer Type: Integrating, Instant Reset (selected)
- Control Mode Limits:**
  - Maximum Voltage Limit: 128.0 (range 95.0 to 140.0 V)
  - Minimum Voltage Limit: 110.0 (range 95.0 to 140.0 V)
  - Definite Time: 10 (range 0 to 60 sec)
  - Disable All: [ ]
  - Enable in Auto: [x]
  - Enable in Remote: [ ]
  - Enable in Manual: [ ]

Buttons at the bottom: Undo/Refresh, Save, Exit.

# Control Mode Overrides and Blocks

## Control Mode

- This is a secondary safety point for voltage Limits. Can be enabled or not.
- If Remote is selected it will block but not Initiate when the control is in remote manual.
- If Manual is selected it will block but not initiate when the control is in manual mode.
- If auto is selected it will block and initiate when the control is in automatic mode.
- Time delay is used for initiating when in Auto mode.

**Setpoints**

Profile 1 | Profile 2 | Profile 3 | Profile 4

**Auto Control Mode**

Enable Voltage Control  
  Enable VAR Control  
  Enable Current Control  
 Classic  
  Autodaptive® Classic  
  Autodaptive® Enhanced

Control Open Voltage: 123.0 (95.0 to 140.0 V)

Control Close Voltage: 117.0 (95.0 to 140.0 V)

Close Definite Time: 30 (0 to 600 Sec)

Open Definite Time: 30 (0 to 600 sec)

Time Delay Selection:  Definite Time    Inverse Time

Basic Timer Type:  Integrating    Instant Reset

Temperature Override   Configure  
  Time Override   Configure

**Remote Control Mode**

Disable Limits  
  Enable Limits

Overvoltage Limit: 126.0 (95.0 to 140.0 V)

Undervoltage Limit: 114.0 (95.0 to 140.0 V)

Definite Voltage Limits Timer: 30 (0 to 600 (Sec))

Time Delay Selection:  Definite Time    Inverse Time

Basic Timer Type:  Integrating    Instant Reset

**Control Mode Limits**

Maximum Voltage Limit: 128.0 (95.0 to 140.0 V)

Minimum Voltage Limit: 110.0 (95.0 to 140.0 V)

Definite Time: 10 (0 to 60 (sec))

Disable All  
  Enable in Auto  
  Enable in Remote  
  Enable in Manual

Undo/Refresh   Save   Exit

# Metering and Status

## Advanced Metering

Metering & Status
\_ □ ×

**Secondary**

Voltage	120	V
Fwd Pwr Delta V	2	V
Rev Pwr Delta V	2	V
Power Factor	0	
Phase Angle	0°	
Neutral Phase Angle	0°	
Frequency	60	Hz

**Close/Open Timer Status**

Close Definite Timer	0	%
Close Warning Delay	0	sec
Re-Close Delay	0	sec

**Temperature**

40.0 °F

**Capacitor Bank Status**

Open

**Battery Low Voltage**

Alarm ●

**RSSI**

RSSI

**Bank Switch Status**

Phase A ●
Phase B ●
Phase C ●

**Intrusion Detection Alarm**

Cabinet Door Open

**Primary**

Voltage	12.2	kV
Neutral Current	2.5	A
Delta Current	0	A
Phase Current	0	A
Watts	0	kW
VAr	0	kVAr
VA	0	KVA

**Alarm Status**

Maximum Voltage Limit		Minimum Voltage Limit	
Remote Overvoltage Limit		Remote Undervoltage Limit	
Bank/Switch Failed Level 2		Bank/Switch Failed Level 1	
Resettable Counter Limit		Daily Operation Counter Limit	
Voltage Harmonics		Current Harmonics	
Remote Manual		Self Test	
Delta Voltage Alarm		THD Lockout Alarm	V   I
Leading VAr	Lagging VAr	Leading PF	Lagging PF

**Control Operations**

Operation Mode	Auto Control
Block Status	Block Open
	HMI Active

**Counters**

Operation Counter	0
Resettable Counter	0
Daily Operation Counter	0

**CBEMA Events and Counter Status**

CBEMA 1	Pickup	0
CBEMA 2	None	0
CBEMA 3	None	0
CBEMA 4	None	0

**Bob McFetridge –Hubbell Utility  
Solutions – Beckwith Electric**

**919-675-3372**

**910-777-4910 Home**

**[bmcfetridge@hubbell.com](mailto:bmcfetridge@hubbell.com)**

**[www.BeckwithElectric.com](http://www.BeckwithElectric.com)**

**(727) 544-2326**